



ACO Pipe



Stainless Steel Push-Fit Pipe Systems

Straights

Bends

Branches

Couplings/Sockets





ACO.

we care for water

The ACO Group

Founded in 1946, the ACO Group is a world leader in drainage technology. Industry changes set us a challenge to react effectively with innovative solutions to new environmental conditions. With its integrated approach, ACO provides systems for professional grade, efficient, and hygienic surface water and building drainage.

Major innovative strengths of the ACO Group are its continuous research and development and technical expertise in the processing of polymer concrete, plastics, cast iron, stainless steel and cement concretes.

ACO in Canada

The ACO group was founded in 1946. ACO Systems, Ltd. was founded in 2006 in Ontario. Since the start, continuous growth in Canada has seen the company expand across all provinces and open an office and warehouse in Vancouver, British Columbia. Today ACO Canada has comprehensive sales and technical personnel and an extensive distribution network serving all provinces and territories.

ACO Building Drainage

ACO offers drainage systems designed to protect your business and the environment. The stainless steel drainage products are corrosion-resistant and built with hygiene in mind, ensuring the health and safety of workers, customers and products while still allowing clean-in-place functionality.

Products include:

- Modular Trench Drains
- Floor Drains
- Slot Drain Systems
- Hygienic push-fit pipes

The background of the page is a close-up, artistic photograph of several stainless steel pipes. The pipes are arranged in a circular pattern, with some in the foreground and others receding into the background, creating a sense of depth. The lighting is soft, highlighting the metallic texture and the circular openings of the pipes.

Contents

1	ACO Pipe Overview	
	Stainless Steel Features & Benefits	03
	Choosing the Right System	06
	Pipe Features & Benefits	07
	Project Planning	09
2	ACO Pipe Products	
	ACO Pipe	13
	Accessories	20
3	Technical Support & Services	
	Installation	24
	Pipework Support Details	26
	Care & Maintenance	27
	Seal Material Data	28

Stainless Steel

Material For Handling Water

MATERIAL TECHNOLOGY

Long Term Value

The properties of stainless steel make it a powerful candidate in material selection. When total life cycle cost is considered, stainless steel is often the least expensive option.

In the building and construction industry, stainless steel is selected due to:

- Resistant to corrosion in wet environments and to cleaning agents
- Resistant to oxidation and scaling while retaining strength at high temperatures
- Easy cleaning makes it the correct choice for hygiene conditions
- Bright and easily maintained surface provides a modern and attractive appearance

These features make stainless steel an obvious choice for demanding drainage applications.



There is a variety of different stainless steels available. Austenitic stainless steels are the most widely used and encompass the generic 304 and 316L grades. These material grades are ideal for many applications found in food processing, dairy, commercial kitchens, pharmaceutical, chemical, winery and brewery industries.

304 grade stainless steel is the most common material available but grade 316L provides superior corrosion resistance and is ideal for conditions where extreme heat or chemicals are used.

Stainless steel is one of the most sustainable material choices available and is 100% recyclable. One benefit is that it reduces the consumption, expenses, energy and time to mine other valuable resources. On average the recycled content of stainless steel is 60%. Recycled stainless steel is beneficial to the environment as it consumes less energy and resources to produce.



PERFORMANCE

Corrosion and Temperature Resistance

Some industrial applications present a challenging environment for drainage systems. All systems featured in this brochure are manufactured from stainless steel grade 316L. Products are finished with a pickle passivation process ensuring corrosion-free welded joints.

Environments where highly aggressive liquids such as acids, alkaline solutions or chlorine bearing agents are used, drainage products must be durable and corrosion resistant. For these applications, ACO recommends stainless steel systems be manufactured using grade 316L stainless steel.

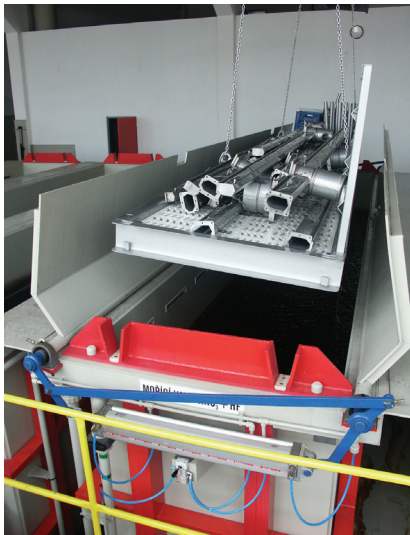

PICKLING & PASSIVATION

Superior Finish and Protection

Bending, cutting, and welding during the manufacturing process results in damage to the stainless surface that can lead to corrosion. Pickling and passivation processes restore physical properties of stainless steel.

- Increases corrosion resistance
- Smooth uniform and attractive appearance
- Extends the life of the product

HYGIENE

Food and Employee Safety

Hygiene requirements can be intense and demanding; from consumption products such as beverage and food preparation, to medical facilities and processing plants.

- Stainless steel is an excellent material suitable for internal and external use for humans and animals, protecting against harmful bacteria and other contaminants
- ACO designs hygienic drains that promote efficient cleaning, protection against microorganisms and bacteria and ultimately minimizing financial risk to you
- ACO applies relevant hygienic design principles reserved for food contact surfaces or recommended by NSF/ANSI and EHEDG

Products shown with the  symbol in the catalog indicate ACO's hygienic design that enhance the hygienic properties of stainless steel.

HygieneFirst

Drainage systems are a particularly important niche for the persistence of listeria and can be a source of food contamination. Poorly specified drainage leads to costly ongoing cleaning and maintenance and at worst it can result in food contamination.

HygieneFirst stands for ACO's commitment to ultimate hygienic performance. ACO addresses the hygienic requirements of floor drains and applies the design principles reserved for food contact equipment on them to deliver fully hygienic solutions.

- ACO is committed to raising industry standards by designing and promoting hygienic products for multiple commercial applications.
- Hygienic drainage systems reduce the risk of food contamination and optimize total cleaning costs of your organization.
- ACO drainage systems prioritize health and safety in the food sector for employees and end users.
- ACO efficient and hygienic designs reduce the usage of volatile cleaning agents that affect indoor air quality while promoting employee safety.

ACO Pipe Stainless Steel System

ACO offers a complete range of stainless steel drainage pipes along with a selection of standard and custom fittings.

ACO Pipe stainless steel socketed pipe systems provide a modern metal alternative to PVC, ABS, and HDPE soil and waste pipework. ACO Pipe is a grade 316L stainless steel push-fit drainage system of pipes and fittings. Ideal for above and below-ground drainage applications.

ACO Pipe offers a unique push-fit feature designed for ease of assembly and installation. ACO Stainless Pipes are nonpressurized and are designed, produced and tested for use in soil, waste, rainwater, and industrial wastewater drainage applications.

ACO Pipe is compatible with ACO floor drains and ACO stainless steel channel systems. ACO Pipe can be welded when required.



ADVANTAGES OF STAINLESS STEEL PIPE

- Corrosion and fire resistant
- Hygienic and easy to maintain
- Will not sag like PVC, ABS, and HDPE
- Will not rust and corrode like cast iron
- Animal (rodent) proof. [See page 20.](#)
- Durable & lightweight material
- 100% recyclable
- Flexible material - Less potential for catastrophic failure (flooding) due to impact damage. Tends to result in bending rather than breakage/flooding.

NON-TOXIC AND FIREPROOF

ACO Pipe push-fit system is designed and manufactured to EN 1124 Parts 1 and 2. It is non-combustible and classified as Class A "No contribution to fire" as provided for in Commission Decision 96/603/EC as amended.

ACO Pipe systems are also certified by the Swedish Institute for Technical Approval in Construction (SITAC) as fire resistant, Certificate No 0410-01.

- Non-combustible
- No additional fire collars needed at installation
- No toxic fumes emitted in case of fire EN 1124, SITAC, CSI, DNV and ABS fire certification available

STANDARDS AND CERTIFICATIONS

ACO Pipe meets the requirements and it is certified to ASME A112.3.1 Stainless Steel Drainage Systems for Sanitary DWV, Storm, And Vacuum Applications, Above and Below Ground.

ACO Pipe is designed, manufactured and tested according to the standards EN 1124-1 and EN 1124-2: Pipes and fittings of longitudinally welded stainless steel pipes with spigot and socket for waste water systems. Additionally, ACO Pipe has been assessed and complies to AS3495: Stainless steel non pressure pipes and fittings.

ACO Pipe has been tested and approved by IAPMO as compliant to Canadian Uniform Plumbing Code (cUPC) and National Plumbing Code of Canada (NPCC).

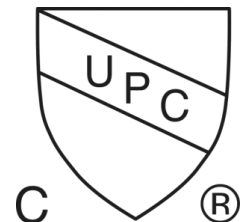

Choosing the Right System

1. ENVIRONMENT - CORROSION

Stainless steel ACO Pipe is offered in non-magnetic austenitic stainless steel grade 316L. All products are pickled and passivated; parts can be electropolished to special order.

Typical factors that affect material selection:

- Types of chemicals
- Concentration percentages
- Contact time
- Temperatures of liquids

Post Fabrication Processes

Heat from welding often causes surface discoloration. The material is no longer as corrosion resistant and is likely to rust and deteriorate.



Bead blasting and/or sanding can restore the aesthetics of the material but does not restore corrosion resistance - a chemical process, such as pickling and passivation is needed.

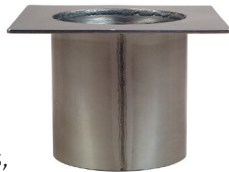

Fabrication processes such as cutting and bending can embed iron particles into the stainless steel - pickling and passivation will also remove these impurities.

Certification to confirm chemical resistance are available, contact ACO.

2. ENVIRONMENT - TEMPERATURE

Applications with high ambient or high fluid temperatures are ideal for stainless steel pipe systems as they offer a low coefficient of thermal expansion.

Thermal Movement

A comparison of approximate thermal movement between different pipe materials in inches per foot (mm per m) with a temperature change of 140°F (60°C) is given below.

Material	in / ft	mm / m
HDPE	0.10800	9.00
CPVC	0.05040	4.20
PVCu	0.03600	3.00
Aluminium Alloy	0.01728	1.44
Stainless Steel	0.01188	0.99
Copper	0.01176	0.98
Cast Iron	0.00900	0.75

3. FLOW CAPACITY

ACO Pipe comes in a wide range of sizes to meet most projects needs, flow tables provided on page 10 provide capacity figures for straight runs. Bends and direction changes significantly impact flow, and are common areas for sediment build up.

Operating Pressure

ACO Pipes and fittings are equipped with a unique double seal. This double seal not only provides added security for long term reliability, but also a benefit for ease of installation.

ACO Pipe is tested and approved for operating pressures in all gravity, syphonic and vacuum systems and is designed for a maximum working pressure between -11.6 psi to 7.25 psi (-0.8 to 0.5 bar).

Socket clamps are available for extreme pressure environments. See page 21.



Features & Benefits

ACO stainless steel pipe systems offer all the key features found in traditional metal rainwater, soil and waste systems plus the unique benefits of stainless steel. ACO's hygienic and push-fit design system ensure a long lasting solution.

- Comprehensive range – selection of straights, bends, branches, coupling and installation hardware.
- Pipe lengths up to 9' 10" (3 m) for diameters from 1.57" (40 mm) to 12.40" (315 mm).
- Ease of installation – components are lightweight and push-fit for quick assembly.
- Optimum joint integrity – components have a low coefficient of thermal expansion compared with plastics which tend to fail when operating temperatures vary between 50°F (10°C) and 140°F (60°C).
- Superior seal security – components comprise a unique double lip sealing system, ideal for extraneous conditions.
- Long service life – components are manufactured from grade 316L stainless steel for high corrosion resistance and low on-going maintenance. The expected service life cycle exceeds 50 years.
- Quality design & construction – components exhibit better geometric concentricity, fitting design and weld quality than any other product in the industry.
- Connection adaptability – components are suitable for easy push-fit connection.
- Hygiene - smooth welding surface quality along with pickling and passivation of all stainless steel products within the ACO Pipe system safeguards against corrosion and allows for easy cleaning.

Pipe Diameters

- 1.97" (50 mm)
 - 2.95" (75 mm)
 - 4.33" (110 mm)
 - 6.30" (160 mm)
 - 7.87" (200 mm)
- available as standard.

Contact ACO for details on:

- 1.57" (40 mm)
 - 9.84" (250 mm)
 - 12.4" (315 mm)
- pipe sizes.

Standard Sections

Available in:

- 5.91" (150 mm)
- 9.84" (250 mm)
- 19.69" (500 mm)
- 29.53" (750 mm)
- 39.37" (1000 mm)
- 59.06" (1500 mm)
- 78.74" (2000 mm)
- 98.43" (2500 mm)
- 118.11" (3000 mm)

lengths for optimum practicality of handling and freight.

Socketed End Profiles

Provide a modular push-fit system, that offers all the time saving benefits of traditional PVC pipe systems.

Wall Thickness

0.04"–0.08" (1–2 mm) minimum provides a lightweight, easy to handle system that can withstand everyday wear and tear.

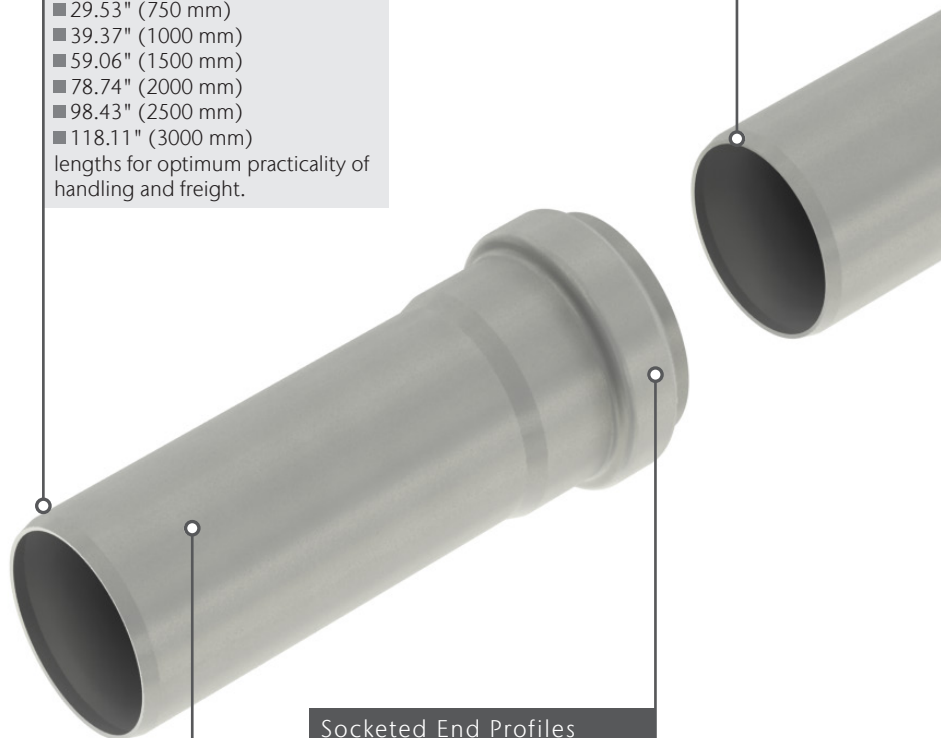

Manufacturing

All components are manufactured using cold-forming techniques which minimize the amount of welding required.



Accessories

Full range of angles, branches, accessories and installation devices reduce amount of on-site cutting and installation time.

Hygienic Benefit of Stainless Steel

Stainless steel is a corrosion-resistant, hygienic, easy to clean material with good strength to weight ratio. See page 4 for more details.

Push-fit

A 10° bevel facilitates easy push fit connection of sections. Where required, all joints can be fully circumferentially welded for extra security.



Seal

A unique double lip seal on all joints ensures a trouble-free, reliable system.

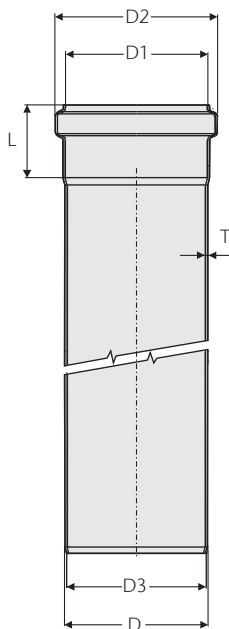

DIMENSIONS OF PIPE SOCKET & SPIGOT

D in (mm)	D1 in (mm)	D2 in (mm)	D3 in (mm)	Socket Length L in (mm)	Wall Thickness T in (mm)
1.57 (40)	1.61 (41)	2.03 (52)	1.46 (37)	1.56 (40)	0.04 (1)
1.97 (50)	2.01 (51)	2.44 (62)	1.85 (47)	1.65 (42)	0.04 (1)
2.95 (75)	2.99 (76)	3.44 (88)	2.83 (72)	1.97 (50)	0.04 (1)
4.33 (110)	4.37 (111)	4.94 (126)	4.21 (107)	2.24 (57)	0.04 (1)
4.92 (125)	4.96 (126)	5.55 (141)	4.80 (122)	2.48 (63)	0.04 (1)
6.30 (160)	6.34 (161)	7.01 (178)	6.14 (156)	2.76 (70)	0.05 (1.25)
7.87 (200)	7.91 (201)	8.62 (219)	7.68 (195)	3.15 (80)	0.06 (1.5)
9.84 (250)	9.88 (251)	10.57 (269)	9.65 (245)	3.53 (90)	0.06 (1.5)
12.40 (315)	12.44 (316)	13.16 (334)	12.20 (310)	3.94 (100)	0.08 (2.0)

Project Planning: Design Tips

- Complete a Risk Assessment of the project to better understand:
 - Costs of spills due to pipe damage
 - Risks associated with vandalism
 - Unexpected increases to flow rates
 - Causes of potential pipe blockages
 - Installation time and location
- Complete a Risk Assessment of application specific environment:
 - Liquid temp and thermal risk
 - Chemicals and acid demands
 - Bacteria Impact to your business
 - Min & max flow rates
- ACO Pipe is tolerant of sudden temperature changes without risk of damage and corrosion resistant.
- Plan for the future and avoid selecting pipe sizes that are close to, or at, current capacities.
- Factor in for variations in rain fall and potential debris entering pipe system to avoid blocking issues and avoid environmental impacts
- Calculate slope, or grade, required of installed pipe system.
 - No or minimal slope will not achieve optimal flow rates.
 - Too much slope can cause backup or blocking issues downstream.
- Document all potential fluid types that will enter the system to determine impact to pipe and seals. Checklist as follows:
 - Identify chemical composition of all fluids.
 - Understand concentration level of each chemical.
 - Confirm maximum temperatures. Given above information, correct seal can be selected. [See pages 21 and 28.](#)
- Review local minimum plumbing code requirements.
- Insert optimal access points for clean-outs for efficient maintenance of system.
- Set maintenance program to avoid damage after installation.
 - Significant damage can impact flow performance and create a problem for sediment and debris build up.
 - Maximize longevity of product and aesthetic appearance.
- ACO Technical Support can help guide through the planning and implementation phase of the project.
- The following standards will assist designers in selecting the correct size of pipe system for a particular application.
 - EN 12056: Gravity Drainage Systems Inside Buildings.
 - EN 752: Drain and Sewer Systems Outside Buildings.
- Refer to [pages 11 and 12](#) for ACO Pipe hydraulic data.

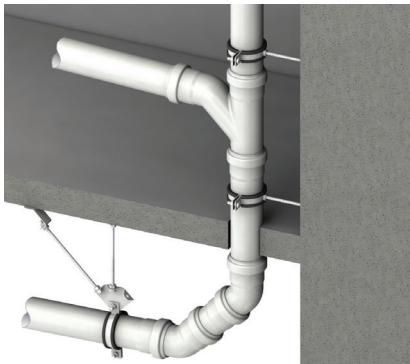

PIPEWORK SUPPORT

Installation should be in accordance with manufacturer's recommendations. EN12056-2, EN12056-3 and EN752. [See page 24.](#)

Designers must ensure that all pipework is supported with brackets according to requirements of your local plumbing codes. [See page 26.](#)

PIPE WEIGHTS

Engineers should be aware of minimum and maximum weights when designing vertical stack and horizontal pipe run systems. [See page 26.](#)

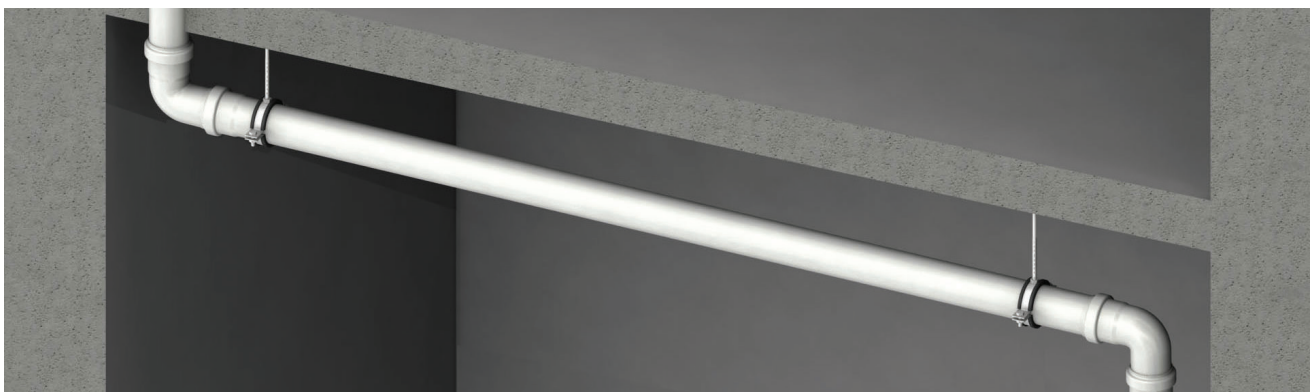

Project Planning: Maintenance Tips

DESIGNING A MAINTENANCE PROGRAM

Pipe systems should be maintained to prevent failures and reduce overall cleaning and maintenance costs. An effective maintenance program will highlight the application specific areas that require the most attention in order to prevent issues.

Additional precautions must be taken with food processing, commercial kitchen, pharmaceutical and chemical industry applications where extremely high levels of cleanliness is required.

FREQUENCY OF CLEANING STAINLESS STEEL

Generally, it is acceptable to clean the metal when dirty to restore original appearance. This may vary from one to four times a year for external applications, or it can be daily in hygienic or aggressive environments.

Stainless steel is easy to clean. Washing with soap or mild detergent and warm water, followed by a clear water rinse is usually adequate for many industrial applications. An enhanced aesthetic appearance will be achieved if the cleaned surface is wiped dry to remove water spots.

If professional maintenance is required (e.g. for building upgrades), stainless steel can be mechanically cleaned or electropolished by specialists on site.

For more information on care and maintenance, see page 27.

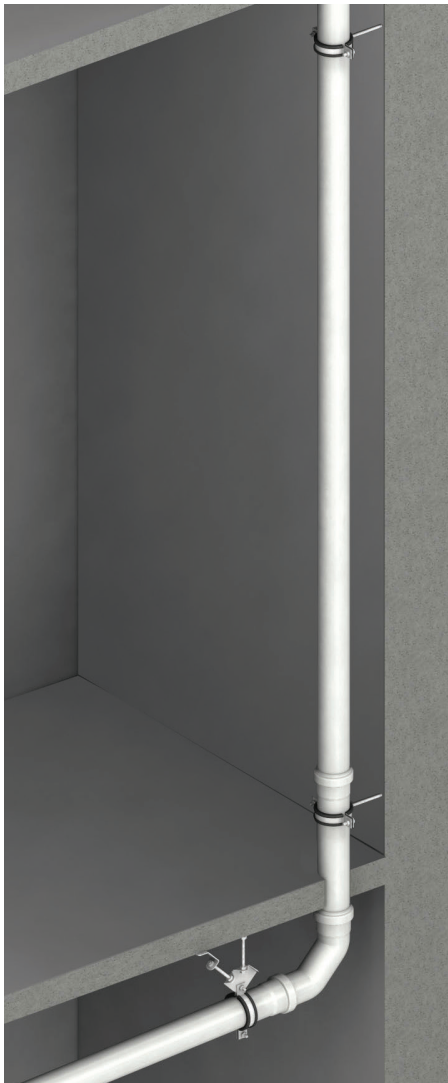

Project Planning: Flow Rate Tips

Compared to cast iron, plastic, clay and vitreous pipe systems, stainless steel pipes have a considerably smoother bore (Manning Coefficient: 0.011) and are less susceptible to internal scaling.

Roughness coefficients of 0.024" (0.6 mm) should be used for rainwater/storm drainage and 0.06" (1.5 mm) for wastewater drainage.

When draining storm or wastewater, it is inevitable that sediment deposits will occur within the drainage system.

Sediment and scale deposits will reduce flow rate through a pipe system. It is recommended that an allowance is made for this during the design and planning phase.

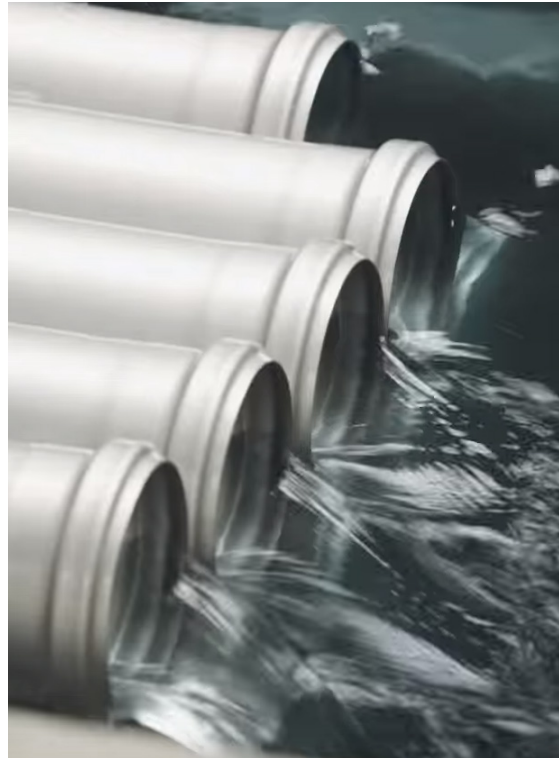

FLOW TABLES

Two sets of flow tables are presented for design use.

Table 1 is for pipes installed with none, or very small gradients where steady, uniform flow equations are inaccurate. The data has been generated from ACO's hydraulic design program "Hydro" that is based on the sequations of spatially-varied flow.

Table 2 is for pipes installed with varying gradients. The data is based on the Colebrook-White equation using an appropriate roughness coefficient for stainless steel.

Table 1: Full Bore Flow Rate Tables for Level (or Nearly Level) Gradients

Flow rates based on a spatially-varied flow formula for steady non-uniform flow. Manning Coefficient 0.011

Pipe Ø / in (mm)	Length ft (m)	Gradient							
		0.0%		0.25%		0.5%		0.75%	
		Q (gpm)	Q l/s	Q (gpm)	Q l/s	Q (gpm)	Q l/s	Q (gpm)	Q l/s
1.97 (50)	16.4 (5)	6	0.4	9	0.6	12	1	15	0.9
	32.8 (10)	5	0.3	9	0.5	12	1	15	0.9
	49.2 (15)	4	0.3	8	0.5	12	1	15	0.9
	65.6 (20)	4	0.2	8	0.5	12	1	15	0.9
2.95 (75)	16.4 (5)	23	1.5	28	1.8	38	2	46	2.9
	32.8 (10)	17	1.1	27	1.7	37	2	46	2.9
	49.2 (15)	15	1.0	27	1.7	37	2	46	2.9
	65.6 (20)	13	0.9	27	1.7	37	2.4	46	2.9
4.33 (110)	16.4 (5)	71	4.5	88	5.6	107	6.8	129	8.2
	32.8 (10)	57	3.6	80	5.1	105	6.6	129	8.2
	49.2 (15)	51	3.2	78	4.9	103	6.5	129	8.2
	65.6 (20)	44	2.8	76	4.8	103	6.5	129	8.2
4.92 (125)	16.4 (5)	102	6.5	125	7.9	152	9.6	181	11.5
	32.8 (10)	82	5.2	115	7.3	151	9.5	181	11.5
	49.2 (15)	72	4.6	111	7.0	151	9.5	181	11.5
	65.6 (20)	65	4.1	109	6.9	151	9.5	181	11.5
6.30 (160)	16.4 (5)	206	13.0	244	15.4	295	18.6	336	21.2
	32.8 (10)	173	10.9	227	14.3	293	18.5	336	21.2
	49.2 (15)	151	9.5	219	13.8	292	18.4	336	21.2
	65.6 (20)	135	8.5	214	13.5	290	18.3	336	21.2
7.87 (200)	16.4 (5)	393	24.8	460	29.0	542	34.2	613	38.7
	32.8 (10)	330	20.8	423	26.7	536	33.8	609	38.4
	49.2 (15)	295	18.6	407	25.7	534	33.7	609	38.4
	65.6 (20)	269	17.0	396	25.0	533	33.6	609	38.4

Using spatially varied flow equations, the length to an outlet will determine the maximum flow rate through the pipe. The flow rates shown above assume an unrestricted discharge from the pipe. For installations without an unrestricted discharge, the flow rate will be affected by the downstream throttle.

Table 2(a-b): Full Bore Flow Rate Velocities for Varying Gradients

Table 2a: For Stormwater Drainage Applications

Flow rates based on a Colebrook-White formula.
Roughness coefficient $k_s = 0.024''$ (0.6 mm)

		Gradient %	10.0	7.5	5.0	4.5	4.0	3.5	3.0	2.5	2.0	1.5	1.0	
Pipe Ø / in (mm)	1.57" (40 mm)	Q	gpm	23	20	17	16	15	14	13	12	10	9	7
			l/s	1.4	1.3	1.0	1.0	0.9	0.8	0.8	0.7	0.6	0.6	0.4
		v	ft/s	4.2	3.7	3	2.9	2.7	2.5	2.3	2.1	1.9	1.7	1.4
			m/s	1.3	1.1	0.9	0.9	0.8	0.8	0.7	0.6	0.6	0.5	0.4
	1.97" (50 mm)	Q	gpm	43	38	31	29	27	26	24	22	19	17	14
			l/s	2.7	2.4	1.9	1.8	1.7	1.6	1.5	1.4	1.2	1.1	0.9
		v	ft/s	5.0	4.3	3.5	3.3	3.1	3.0	2.7	2.5	2.2	1.9	1.6
			m/s	1.5	1.3	1.1	1.0	1.0	0.9	0.8	0.8	0.7	0.6	0.5
	2.95" (75 mm)	Q	gpm	133	115	94	89	84	79	73	67	60	52	42
			l/s	8.4	7.3	5.9	5.6	5.3	5.0	4.6	4.2	3.8	3.3	2.7
		v	ft/s	6.6	5.7	4.7	4.4	4.2	3.9	3.6	3.3	3.0	2.6	2.1
			m/s	2.0	1.7	1.4	1.4	1.3	1.2	1.1	1.0	0.9	0.8	0.6
4.33" (110 mm)	Q	gpm	377	327	267	253	239	223	207	189	169	146	119	
		l/s	23.8	20.6	16.8	16.0	15.1	14.1	13.0	11.9	10.6	9.2	7.5	
	v	ft/s	8.5	7.4	6.0	5.7	5.4	5.1	4.7	4.3	3.8	3.3	2.7	
		m/s	2.6	2.3	1.8	1.7	1.6	1.5	1.4	1.3	1.2	1.0	0.8	
4.92" (125 mm)	Q	gpm	533	461	377	357	337	315	292	266	238	206	168	
		l/s	33.6	29.1	23.8	22.6	21.3	19.9	18.4	16.8	15.0	13.0	10.6	
	v	ft/s	9.3	8.0	6.6	6.2	5.9	5.5	5.1	4.6	4.1	3.6	2.9	
		m/s	2.8	2.5	2.0	1.9	1.8	1.7	1.6	1.4	1.3	1.1	0.9	
6.30" (160 mm)	Q	gpm	1,017	881	719	682	643	602	557	508	455	394	321	
		l/s	64.2	55.6	45.4	43.0	40.6	38.0	35.1	32.1	28.7	24.8	20.3	
	v	ft/s	10.9	9.4	7.7	7.3	6.9	6.4	5.9	5.4	4.9	4.2	3.4	
		m/s	3.3	2.9	2.3	2.2	2.1	2.0	1.8	1.7	1.5	1.3	1.1	
7.87" (200 mm)	Q	gpm	1,853	1,604	1,310	1,243	1,172	1,096	1,015	926	828	717	586	
		l/s	116.9	101.2	82.7	78.4	73.9	69.1	64.0	58.4	52.3	45.3	37.0	
	v	ft/s	12.6	10.9	8.9	8.4	8.0	7.4	6.9	6.3	5.6	4.9	4.0	
		m/s	3.8	3.3	2.7	2.6	2.4	2.3	2.1	1.9	1.7	1.5	1.2	
9.84" (250 mm)	Q	gpm	3,461	2,995	2,443	2,317	2,184	2,042	1,890	1,724	1,541	1,333	1,086	
		l/s	218.3	189.0	154.1	146.2	137.8	128.8	119.2	108.7	97.2	84.1	68.5	
	v	ft/s	14.6	12.7	10.3	9.8	9.3	8.7	8.0	7.3	6.5	5.7	4.6	
		m/s	4.5	3.9	3.1	3.0	2.8	2.6	2.4	2.2	2.0	1.7	1.4	
12.40" (315 mm)	Q	gpm	6,364	5,509	4,494	4,263	4,018	3,757	3,477	3,172	2,835	2,452	1,999	
		l/s	401.5	347.5	283.5	268.9	253.5	237.0	219.3	200.1	178.8	154.7	126.1	
	v	ft/s	18.1	14.7	12	11.4	10.7	10	9.3	8.5	7.6	6.6	5.4	

Table 2b: For Wastewater Drainage Applications

Flow rates based on a Colebrook-White formula.
Roughness coefficient $k_s = 0.024''$ (0.6 mm)

		Gradient %	10.0	7.5	5.0	3.5	3.0	2.5	2.0	1.5	1.0	
Pipe Ø / in (mm)	1.57" (40 mm)	Q	gpm	20	17	14	12	11	10	9	8	6
			l/s	1.2	1.0	0.9	0.7	0.7	0.6	0.5	0.5	0.4
		v	ft/s	3.6	3.1	2.5	2.1	2	1.8	1.6	1.4	1.2
			m/s	1.1	0.9	0.8	0.6	0.6	0.5	0.5	0.4	0.3
	1.97" (50 mm)	Q	gpm	36	32	25	22	20	18	16	14	12
			l/s	2.3	2.0	1.6	1.4	1.3	1.2	1.0	0.9	0.7
		v	ft/s	4.2	3.6	2.6	2.5	2.3	2.1	1.9	1.6	1.3
			m/s	1.3	1.1	0.8	0.8	0.7	0.6	0.6	0.5	0.4
	2.95" (75 mm)	Q	gpm	113	98	72	67	62	57	51	44	36
			l/s	7.1	6.2	4.5	4.2	3.9	3.6	3.2	2.8	2.3
		v	ft/s	5.6	4.9	3.5	3.3	3.1	2.8	2.5	2.2	1.8
			m/s	1.7	1.5	1.1	1.0	0.9	0.9	0.8	0.7	0.5
4.33" (110 mm)	Q	gpm	324	281	205	192	178	162	145	126	103	
		l/s	20.5	17.7	12.9	12.1	11.2	10.2	9.2	7.9	6.5	
	v	ft/s	7.3	6.3	4.6	4.3	4.0	3.7	3.3	2.8	2.3	
		m/s	2.2	1.9	1.4	1.3	1.2	1.1	1.0	0.9	0.7	
4.92" (125 mm)	Q	gpm	459	398	290	272	252	230	205	178	145	
		l/s	29.0	25.1	18.3	17.1	15.9	14.5	13.0	11.2	9.2	
	v	ft/s	8.0	6.9	5.1	4.7	4.4	4.0	3.6	3.1	2.5	
		m/s	2.4	2.1	1.5	1.4	1.3	1.2	1.1	0.9	0.8	
6.30" (160 mm)	Q	gpm	881	763	557	521	483	441	394	341	279	
		l/s	55.6	48.2	35.2	32.9	30.5	27.8	24.9	21.5	17.6	
	v	ft/s	9.4	8.2	6.0	5.6	5.2	4.7	4.2	3.6	3.0	
		m/s	2.9	2.5	1.8	1.7	1.6	1.4	1.3	1.1	0.9	
7.87" (200 mm)	Q	gpm	1,614	1,398	1,021	955	884	807	722	625	510	
		l/s	101.8	88.2	64.4	60.2	55.8	50.9	45.5	39.4	32.2	
	v	ft/s	11.0	9.5	6.9	6.5	6.0	5.5	4.9	4.2	3.5	
		m/s	3.3	2.9	2.1	2.0	1.8	1.7	1.5	1.3	1.1	
9.84" (250 mm)	Q	gpm	3,279	2,819	2,275	1,882	1,733	1,571	1,393	1,192	955	
		l/s	206.9	177.8	143.5	118.7	109.3	99.1	87.9	75.2	60.3	
	v	ft/s	13.9	11.9	9.7	8.0	7.4	6.7	5.9	5.1	4.1	
		m/s	4.2	3.6	2.9	2.4	2.2	2.0	1.8	1.5	1.2	
12.40" (315 mm)	Q	gpm	6,070	5,223	4,220	3,494	3,219	2,921	2,592	2,220	1,782	
		l/s	383.0	329.5	266.2	220.4	203.1	184.3	164.0	140.1	112.4	
	v	ft/s	16.2	13.9	11.3	9.3	8.6	7.8	6.9	6.0	4.8	

Parts Tables: Straights

		Part No. AISI 316L	D in (mm)	Active Length L in (mm)	Weight lbs
Socketed Pipes 1.57" (40 mm)		417320	1.57 (40)	5.91 (150)	0.5
		417322	1.57 (40)	9.84 (250)	0.8
		417324	1.57 (40)	19.69 (500)	1.5
		417326	1.57 (40)	29.53 (750)	1.9
		417328	1.57 (40)	39.37 (1000)	2.4
		417330	1.57 (40)	59.06 (1500)	3.4
		417332	1.57 (40)	78.74 (2000)	4.5
		417262	1.57 (40)	98.43 (2500)	5.6
		417334	1.57 (40)	118.11 (3000)	6.6

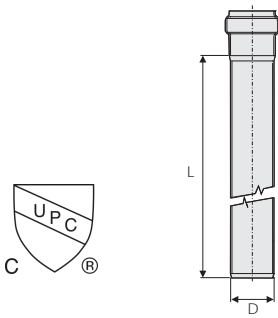

Socketed Pipes 1.97" (50 mm)		98550	1.97 (50)	5.91 (150)	0.4
		98552	1.97 (50)	9.84 (250)	0.9
		98554	1.97 (50)	19.69 (500)	1.5
		98556	1.97 (50)	29.53 (750)	2.2
		98558	1.97 (50)	39.37 (1000)	2.9
		98560	1.97 (50)	59.06 (1500)	4.2
		98562	1.97 (50)	78.74 (2000)	5.7
		419282	1.97 (50)	98.43 (2500)	7.0
		98564	1.97 (50)	118.11 (3000)	8.4

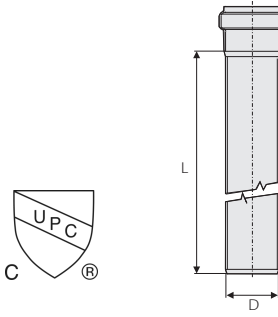

		Part No. AISI 316L	D in (mm)	Active Length L in (mm)	Weight lbs
Socketed Pipes 2.95" (75 mm)		98566	2.95 (75)	5.91 (150)	0.9
		98568	2.95 (75)	9.84 (250)	1.3
		98570	2.95 (75)	19.69 (500)	2.2
		98572	2.95 (75)	29.53 (750)	3.3
		98574	2.95 (75)	39.37 (1000)	4.4
		98576	2.95 (75)	59.06 (1500)	6.4
		98578	2.95 (75)	78.74 (2000)	7.9
		419284	2.95 (75)	98.43 (2500)	10.6
		98580	2.95 (75)	118.11 (3000)	12.5

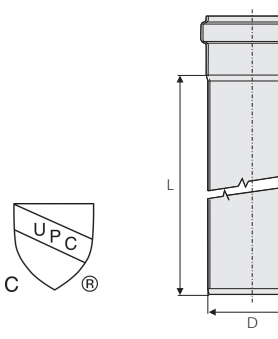

Socketed Pipes 4.33" (110 mm)		98582	4.33 (110)	5.91 (150)	1.3
		98584	4.33 (110)	9.84 (250)	2.0
		98586	4.33 (110)	19.69 (500)	3.3
		98588	4.33 (110)	29.53 (750)	4.8
		98590	4.33 (110)	39.37 (1000)	6.4
		98592	4.33 (110)	59.06 (1500)	9.5
		98594	4.33 (110)	78.74 (2000)	12.5
		419286	4.33 (110)	98.43 (2500)	15.6
		98596	4.33 (110)	118.11 (3000)	18.5

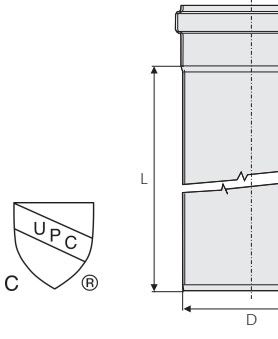

Parts Tables: Straights (cont.)

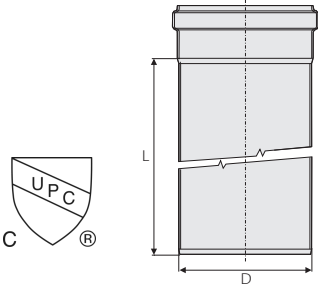
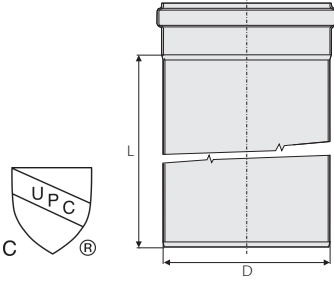
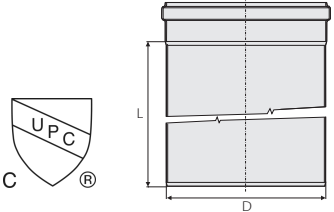
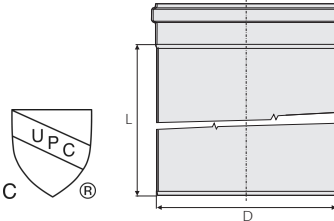
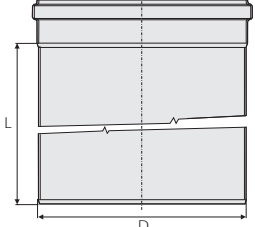
	Part No. AISI 316L	D in (mm)	Active Length L in (mm)	Weight lbs
Socketed Pipes 4.92" (125 mm)				
	419712	4.92 (125)	5.91 (150)	1.5
	419714	4.92 (125)	9.84 (250)	2.2
	419716	4.92 (125)	19.69 (500)	3.8
	419718	4.92 (125)	29.53 (750)	5.5
	419720	4.92 (125)	39.37 (1000)	7.3
	419722	4.92 (125)	59.06 (1500)	10.8
	419724	4.92 (125)	78.74 (2000)	14.3
	419728	4.92 (125)	98.43 (2500)	17.8
	419726	4.92 (125)	118.11 (3000)	21.1
Socketed Pipes 6.30" (160 mm)				
	98598	6.30 (160)	5.91 (150)	2.4
	98650	6.30 (160)	9.84 (250)	3.5
	98652	6.30 (160)	19.69 (500)	6.4
	98654	6.30 (160)	29.53 (750)	9.0
	98656	6.30 (160)	39.37 (1000)	11.9
	98658	6.30 (160)	59.06 (1500)	17.4
	98660	6.30 (160)	78.74 (2000)	22.9
	419288	6.30 (160)	98.43 (2500)	28.4
	98662	6.30 (160)	118.11 (3000)	33.9
Socketed Pipes 7.87" (200 mm)				
	419384	7.87 (200)	19.69 (500)	9.9
	419388	7.87 (200)	39.37 (1000)	18.3
	419392	7.87 (200)	78.74 (2000)	34.8
	419396	7.87 (200)	118.11 (3000)	51.0
Socketed Pipes 9.84" (250 mm)				
	417072	9.84 (250)	19.69 (500)	12.1
	417076	9.84 (250)	39.37 (1000)	22.4
	417080	9.84 (250)	78.74 (2000)	43.6
	417084	9.84 (250)	118.11 (3000)	63.8
Socketed Pipes 12.40" (315 mm)				
	417200	12.40 (315)	19.69 (500)	21.5
	417201	12.40 (315)	39.37 (1000)	38.9
	417202	12.40 (315)	78.74 (2000)	73.7
	417203	12.40 (315)	118.11 (3000)	108.5

EPDM seals are supplied as standard. For more aggressive applications, FPM & NBR seals are available. Contact ACO.

Parts Tables: Bends

Bend 87.5° (Elbow)

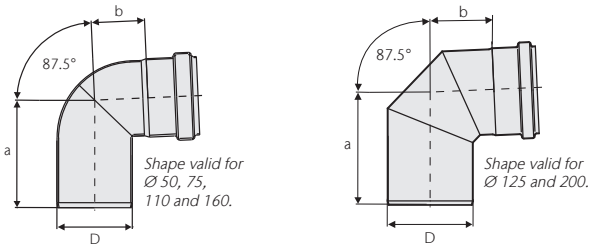

Bend 45°

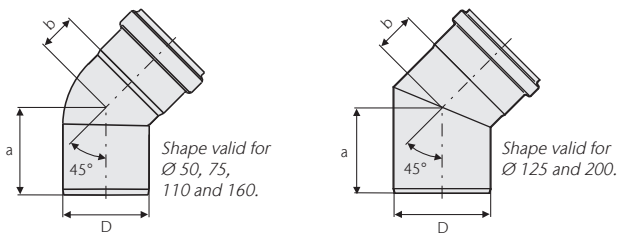

Bend 30°

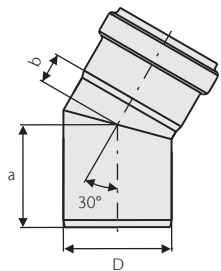

Bend 15°

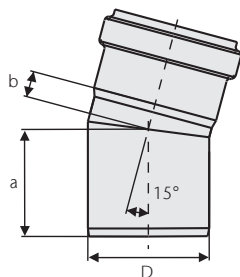

Long Bend 87.5°

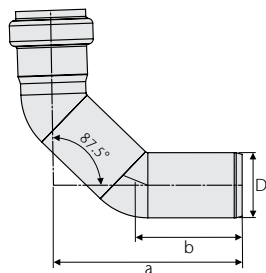

Part No. AISI 316L	D in (mm)	a in (mm)	b in (mm)	Weight lbs
417350	1.57 (40)	3.1 (79)	1.3 (32)	0.5
98750	1.97 (50)	3.4 (86)	1.6 (40)	0.5
98752	2.95 (75)	4.2 (107)	2.1 (53)	1.0
98754	4.33 (110)	5.3 (134)	2.6 (67)	1.7
419734	4.92 (125)	6.3 (161)	3.7 (93)	2.2
98756	6.30 (160)	7.1 (181)	4.1 (105)	4.3
419413	7.87 (200)	8.5 (215)	5.1 (129)	6.8
417088	9.84 (250)	11.7 (297)	7.8 (198)	11.6
417204	12.40 (315)	15.5 (393)	11.3 (286)	28.2
417352	1.57 (40)	2.3 (58)	0.8 (21)	0.4
98758	1.97 (50)	2.4 (62)	0.9 (24)	0.4
98760	2.95 (75)	3.0 (76)	1.3 (32)	0.8
98762	4.33 (110)	3.7 (93)	1.7 (42)	1.4
419738	4.92 (125)	4.3 (110)	2.0 (50)	1.7
98764	6.30 (160)	5.2 (131)	2.2 (55)	3.4
419409	7.87 (200)	6.0 (152)	2.4 (60)	5.2
417092	9.84 (250)	7.0 (177)	3.0 (76)	7.5
417205	12.40 (315)	7.8 (199)	3.6 (91)	15.8
417354	1.57 (40)	2.2 (55)	0.6 (14)	0.2
98766	1.97 (50)	2.2 (57)	0.6 (16)	0.4
98768	2.95 (75)	2.8 (71)	0.8 (21)	0.7
98770	4.33 (110)	3.3 (85)	1.1 (27)	1.1
419742	4.92 (125)	3.9 (98)	1.1 (28)	1.3
98772	6.30 (160)	4.3 (110)	1.6 (40)	2.6
419405	7.87 (200)	5.4 (137)	1.8 (45)	5.1
417096	9.84 (250)	6.0 (153)	2.3 (58)	6.4
417206	12.40 (315)	6.8 (172)	2.7 (68)	12.8
417356	1.57 (40)	2.1 (53)	0.4 (11)	0.3
98774	1.97 (50)	2.1 (54)	0.5 (12)	0.4
98776	2.95 (75)	2.6 (66)	0.6 (16)	0.7
98778	4.33 (110)	3.1 (78)	0.6 (15)	1.1
419746	4.92 (125)	3.3 (84)	0.7 (19)	1.3
98780	6.30 (160)	3.9 (99)	1.1 (29)	2.4
419401	7.87 (200)	4.8 (123)	1.2 (31)	4.2
417100	9.84 (250)	5.4 (136)	1.6 (40)	5.9
417207	12.40 (315)	5.9 (151)	1.8 (46)	11.8
417338	1.57 (40)	4.1 (105)	2.5 (64)	0.6
419000	1.97 (50)	4.84 (123)	2.80 (71)	0.6
419002	2.95 (75)	5.75 (146)	3.43 (87)	1.2
419004	4.33 (110)	12.44 (316)	4.06 (103)	3.2
419144	6.30 (160)	14.17 (360)	4.96 (126)	7.1

Parts Tables: Branches

	Part No. AISI 316L	D in (mm)	a in (mm)	b in (mm)	Weight lbs
Single Branch 87.5° (Single Branch Tee)	417368	1.57 (40)	4.0 (101)	2.7 (69)	0.6
	98782	1.97 (50)	3.4 (86)	1.6 (40)	0.6
	98784	2.95 (75)	4.2 (107)	2.1 (53)	1.1
	98786	4.33 (110)	5.3 (134)	2.6 (67)	2.0
	419750	4.92 (125)	6.3 (161)	3.7 (93)	2.9
	98788	6.30 (160)	7.1 (181)	4.1 (105)	5.3
	419421	7.87 (200)	8.5 (215)	5.1 (129)	9.5
	417104	9.84 (250)	14.3 (363)	8.5 (215)	12.8
	417208	12.40 (315)	18.7 (476)	11.1 (281)	32.5

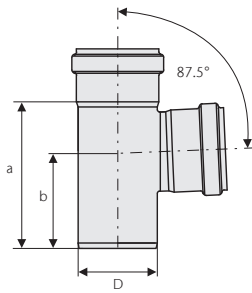

	Part No. AISI 316L	D1 in (mm)	D2 in (mm)	a in (mm)	b in (mm)	Weight lbs
Single Reduction Branch 87.5° (Single Reduction Tee)	417443	1.97 (50)	1.57 (40)	4.2 (106)	3.9 (98)	0.7
	417445	2.95 (75)	1.57 (40)	5.5 (139)	3.9 (98)	0.8
	98930	2.95 (75)	1.97 (50)	5.5 (139)	3.5 (90)	1.0
	98934	4.33 (110)	1.97 (50)	7.2 (183)	4.6 (117)	1.8
	98938	4.33 (110)	2.95 (75)	7.2 (183)	4.6 (117)	1.9
	419754	4.92 (125)	2.95 (75)	7.4 (187)	4.3 (110)	2.2
	419758	4.92 (125)	4.33 (110)	8.1 (206)	5.0 (127)	2.9
	400693	6.30 (160)	4.33 (110)	11.3 (288)	7.2 (184)	4.6
	419417	7.87 (200)	6.30 (160)	11.5 (293)	7.3 (186)	7.4
	417112	9.84 (250)	7.87 (200)	13.7 (349)	8.9 (226)	12.2
	417210	12.40 (315)	9.84 (250)	16.2 (411)	9.8 (248)	23.1

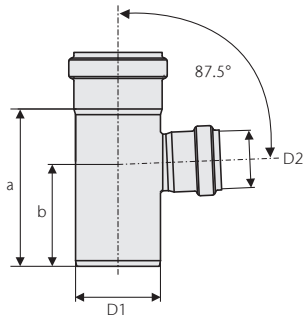

Double Reduction Branch 87.5° (Double Reduction Tee)	98942	2.95 (75)	1.97 (50)	5.5 (139)	3.5 (90)	0.7
	98946	4.33 (110)	1.97 (50)	7.2 (183)	4.6 (117)	1.3
	98902	4.33 (110)	2.95 (75)	7.2 (183)	4.6 (117)	2.0
	400697	6.30 (160)	4.33 (110)	11.3 (288)	7.2 (184)	5.9

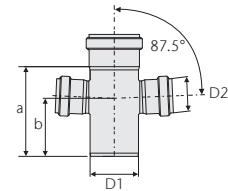

	Part No. AISI 316L	D in (mm)	a in (mm)	b in (mm)	c in (mm)	Weight lbs
Swept Single Branch 87.5° (Long Sweep Tee)	417380	1.57 (40)	4.5 (115)	2.2 (55)	4.1 (105)	0.8
	98864	1.97 (50)	5.0 (128)	2.2 (57)	4.6 (117)	0.8
	98866	2.95 (75)	7.0 (179)	2.9 (74)	6.2 (157)	1.7
	98868	4.33 (110)	9.2 (233)	3.5 (88)	8.2 (209)	3.1
	98870	6.30 (160)	13.1 (332)	7.2 (184)	11.9 (302)	8.3

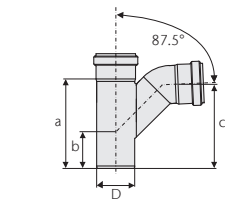

Single Branch 45° (Single Branch Wye)	417372	1.57 (40)	4.6 (118)	2.3 (58)	2.5 (63)	0.7
	98798	1.97 (50)	5.0 (128)	2.2 (57)	3.0 (76)	0.7
	98850	2.95 (75)	7.0 (179)	2.9 (74)	4.3 (110)	1.5
	98852	4.33 (110)	9.2 (233)	3.5 (88)	5.9 (149)	2.7
	419762	4.92 (125)	10.7 (273)	4.1 (103)	6.7 (170)	4.0
	98854	6.30 (160)	13.1 (332)	4.7 (119)	8.7 (222)	7.1
	419429	7.87 (200)	16.3 (415)	5.9 (151)	10.8 (274)	13
	417108	9.84 (250)	20.2 (513)	6.8 (172)	13.2 (336)	19.6
	417209	12.40 (315)	24.3 (616)	7.7 (195)	20.5 (521)	45.3

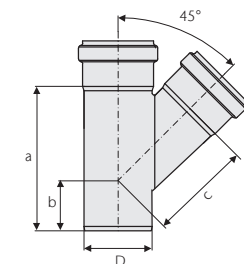

EPDM seals are supplied as standard. For more aggressive applications, FPM & NBR seals are available. Contact ACO.

Parts Tables: Branches (cont.)

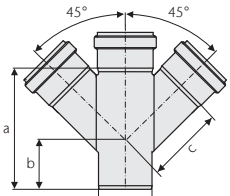
	Part No. AISI 316L	D in (mm)	a in (mm)	b in (mm)	c in (mm)	Weight lbs
Double Branch 45° (Double Branch Wye) 	417378	1.57 (40)	4.6 (118)	2.3 (58)	2.5 (63)	0.9
	98856	1.97 (50)	5.0 (128)	2.2 (57)	3.0 (76)	0.9
	98858	2.95 (75)	7.0 (179)	2.9 (74)	4.3 (110)	1.9
	98860	4.33 (110)	9.2 (233)	3.5 (88)	5.9 (149)	3.4
	98862	6.30 (160)	13.1 (332)	7.2 (184)	8.7 (222)	9.4
	417120	9.84 (250)	20.0 (509)	6.8 (172)	13.2 (336)	25.1
	417212	12.40 (315)	24.3 (616)	7.7 (195)	20.5 (521)	65.4

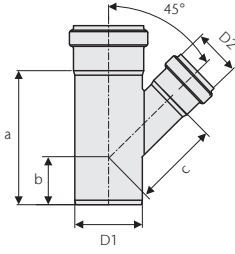
	Part No. AISI 316L	D1 in (mm)	D2 in (mm)	a in (mm)	b in (mm)	c in (mm)	Weight lbs
Single Reduction Branch 45° (Single Reduction Wye) 	417408	1.97 (50)	1.57 (40)	4.7 (119)	2.2 (55)	2.8 (71)	0.8
	417447	2.95 (75)	1.57 (40)	5.7 (144)	2.2 (56)	3.7 (94)	1.3
	400663	2.95 (75)	1.97 (50)	5.7 (144)	2.2 (56)	3.7 (94)	1.1
	400667	4.33 (110)	1.97 (50)	5.8 (147)	1.7 (42)	4.7 (119)	1.6
	400671	4.33 (110)	2.95 (75)	7.2 (182)	2.4 (60)	5.3 (135)	2.0
	419766	4.92 (125)	2.95 (75)	7.9 (200)	2.6 (65)	5.6 (141)	2.4
	419770	4.92 (125)	4.33 (110)	9.8 (250)	3.5 (90)	6.3 (160)	3.1
	400701	6.30 (160)	4.33 (110)	13.1 (332)	4.7 (119)	7.5 (191)	5.6
	419425	7.87 (200)	6.30 (160)	14.1 (359)	4.8 (123)	9.8 (250)	9.7
	417116	9.84 (250)	7.87 (200)	16.9 (429)	6.9 (175)	12.1 (307)	14.8
	417211	12.40 (315)	9.84 (250)	20.2 (513)	5.9 (149)	15.0 (382)	30.7

Double Reduction Branch 45° (Double Reduction Wye) 	400675	2.95 (75)	1.97 (50)	5.7 (144)	2.2 (56)	3.7 (94)	1.6
	400679	4.33 (110)	1.97 (50)	5.8 (147)	1.7 (42)	4.7 (119)	2.0
	400683	4.33 (110)	2.95 (75)	7.2 (182)	2.4 (60)	5.3 (135)	2.5
	400705	6.30 (160)	4.33 (110)	13.1 (332)	4.7 (119)	7.5 (190)	5.0
	417124	9.84 (250)	7.87 (200)	16.9 (429)	5.9 (150)	12.1 (307)	18.4
	417213	12.40 (315)	9.84 (250)	20.2 (513)	5.9 (149)	15.0 (382)	39.2

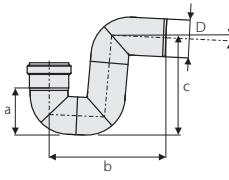
	Part No. AISI 316L	D in (mm)	a in (mm)	b in (mm)	c in (mm)	Weight lbs
P-Trap 	98872	1.97 (50)	2.7 (68)	7.4 (187)	5.9 (149)	1.1
	98874	2.95 (75)	3.7 (94)	9.1 (232)	7.6 (193)	2.2
	98876	4.33 (110)	5.2 (132)	11.8 (300)	10.0 (254)	3.9
	98878	6.30 (160)	7.5 (190)	15.9 (404)	13.7 (347)	10.2
	417487	1.97 (50)	3.6 (92)	7.7 (195)	6.3 (159)	1.3
	417488	2.95 (75)	4.4 (112)	9.1 (232)	7.6 (193)	2.4
	417489	4.33 (110)	6.0 (152)	11.7 (298)	2.1 (54)	4.2
	417490	6.30 (160)	8.0 (204)	15.5 (394)	13.8 (351)	10.9

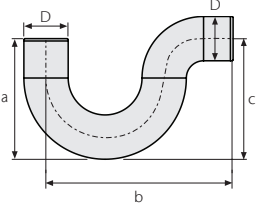
	Part No.	D in (mm)	a in (mm)	b in (mm)	c in (mm)	Weight lbs
Long Sweep P-Trap 	448850	3.50 (88.9)	11.25 (286)	15.0 (381)	9.25 (235)	9.6
	448851	4.50 (114.3)	17.75 (451)	19.0 (483)	12.25 (311)	17.6
	448852	6.625 (168.3)	21.8 (554)	27.0 (686)	18.31 (465)	38.8
	448853	8.625 (219)	28.8 (732)	35.0 (889)	24.31 (617)	73.5
	448854	10.75 (273)	35.87 (911)	43.0 (1092)	30.38 (772)	126.6
	448855	12.75 (324)	42.87 (1089)	51.0 (1295)	36.38 (924)	195.5
	448856	3.50 (88.9)	11.25 (286)	15.0 (381)	9.25 (235)	15.6
	448857	4.50 (114.3)	17.75 (451)	19.0 (483)	12.25 (311)	28.9
	448858	6.625 (168.3)	21.8 (554)	27.0 (686)	18.31 (465)	74.1
	448859	8.625 (219)	28.8 (732)	35.0 (889)	24.31 (617)	146.5
	448860	10.75 (273)	35.87 (911)	43.0 (1092)	30.38 (772)	257.4
	448861	12.75 (324)	42.87 (1089)	51.0 (1295)	36.38 (924)	376.5

Parts Tables: Couplings/Sockets

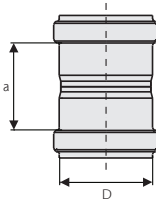
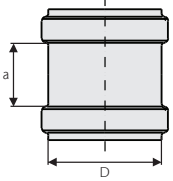
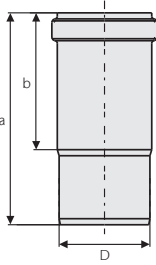
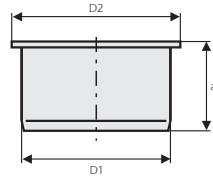
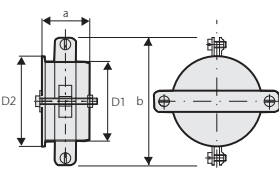
	Part No. AISI 316L	D in (mm)	a in (mm)	Weight lbs		
Straight Coupling  <p>Straight couplings are used to connect two male end pipe sections.</p>	417394	1.57 (40)	2.0 (51)	0.4		
	98970	1.97 (50)	2.1 (54)	0.4		
	98972	2.95 (75)	3.0 (75)	0.6		
	98974	4.33 (110)	3.3 (84)	1.1		
	419815	4.92 (125)	5.5 (140)	1.3		
	98976	6.30 (160)	4.3 (110)	2.2		
	419433	7.87 (200)	5.4 (136)	4.0		
	417160	9.84 (250)	7.1 (181)	5.9		
	417225	12.40 (315)	7.0 (179)	11.4		
Repair Coupling  <p>Repair couplings are used to aid a convenient repair to a damaged in-situ pipe. Unlike the standard straight coupling, there is no central registration to limit the insertion depth of the pipe. The repair coupling slides completely over a pipe joint and simply re-positioned to bridge the required pipe joint.</p> <p>Installation tip: mark the final position of the repair coupling on the installed pipe system to ensure the coupling seals are positioned symmetrically about the pipe joint.</p>	417390	1.57 (40)	2.3 (57)	0.3		
	98880	1.97 (50)	1.7 (44)	0.3		
	98882	2.95 (75)	1.8 (46)	0.5		
	98884	4.33 (110)	2.0 (52)	0.9		
	419774	4.92 (125)	2.8 (70)	1.1		
	98886	6.30 (160)	3.0 (76)	1.9		
	419437	7.87 (200)	3.9 (100)	3.5		
	417139	9.84 (250)	7.2 (182)	5.9		
	417220	12.40 (315)	7.0 (179)	10.8		
Expansion Sockets 	417384	1.57 (40)	5.9 (150)	3.5 (90)	0.5	
	98666	1.97 (50)	3.4 (86)	1.6 (40)	0.5	
	98670	2.95 (75)	4.2 (107)	2.1 (53)	0.8	
	98674	4.33 (110)	5.3 (134)	2.6 (67)	1.3	
	419778	4.92 (125)	6.3 (161)	3.7 (93)	1.9	
	98678	6.30 (160)	7.1 (181)	4.1 (105)	3.5	
	417196	7.87 (200)	8.5 (215)	5.1 (129)	6.6	
	417143	9.84 (250)	15.7 (400)	7.5 (190)	8.7	
	417221	12.40 (315)	17.7 (450)	7.9 (200)	15.9	
		Part No. AISI 316L	D1 in (mm)	D2 in (mm)	a in (mm)	Weight lbs
Socket Plugs 	417405	1.57 (40)	2.0 (50)	2.0 (50)	0.2	
	98888	1.97 (50)	2.3 (58)	1.8 (45)	0.2	
	98889	2.95 (75)	3.4 (85)	1.8 (45)	0.5	
	98890	4.33 (110)	4.7 (120)	1.8 (45)	0.9	
	419782	4.92 (125)	5.3 (135)	2.0 (50)	1.1	
	98891	6.30 (160)	6.7 (170)	2.0 (50)	1.7	
	98994	7.87 (200)	8.3 (210)	2.0 (50)	2.6	
	417131	9.84 (250)	10.2 (260)	3.3 (83)	4.2	
	417215	12.40 (315)	12.8 (325)	2.9 (73)	4.9	
		Part No. AISI 316L	D1 in (mm)	D2 in (mm)	a in (mm)	b in (mm)
Socket Plugs with Clamp 	417402	1.57 (40)	2.3 (58)	2.0 (50)	3.5 (88)	0.6
	419138	1.97 (50)	3.5 (88)	1.8 (45)	3.5 (88)	0.6
	419139	2.95 (75)	4.7 (120)	1.8 (45)	4.7 (120)	1.0
	419140	4.33 (110)	6.6 (167)	1.8 (45)	6.6 (167)	1.5
	419141	6.30 (160)	8.4 (214)	2.0 (50)	8.4 (214)	2.5
	419455	7.87 (200)	10.0 (254)	2.3 (58)	10.0 (254)	3.5
	417132	9.84 (250)	11.9 (302)	3.3 (83)	11.9 (302)	5.2
	417216	12.40 (315)	14.6 (371)	5.1 (130)	14.6 (371)	8.1

EPDM seals are supplied as standard. For more aggressive applications, FPM & NBR seals are available. Contact ACO.

Parts Tables: Couplings/Sockets (cont.)

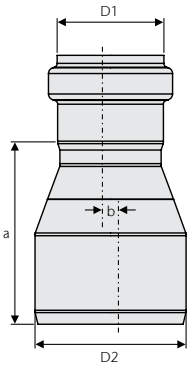
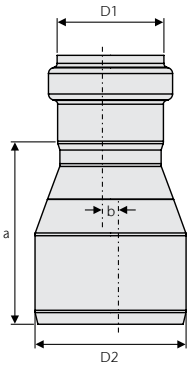
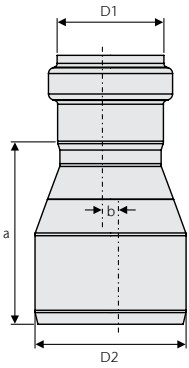
		Part No. AISI 316L	D1 in (mm)	D2 in (mm)	a in (mm)	b in (mm)	Weight lbs	
Concentric Couplings		417491	2.38 (60)	1.97 (50)	2.02 (51)	0	0.5	
		417492	3.50 (89)	2.95 (75)	2.43 (62)	0	0.9	
		Imperial to Metric	417493	4.50 (114)	4.33 (110)	2.72 (69)	0	1.4
			417494	6.63 (168)	6.30 (160)	3.46 (88)	0	2.8
		417495	8.63 (219)	7.87 (200)	2.74 (70)	0	6.6	
				Metric to Imperial	417541	1.57 (40)	1.90 (48)	2.01 (51)
417501	1.97 (50)				2.38 (60)	1.46 (37)	0	0.5
417502	2.95 (75)				3.50 (89)	3.39 (86)	0	0.9
417503	4.33 (110)				4.50 (114)	3.16 (80)	0	1.4
417504	6.30 (160)				6.63 (168)	4.33 (110)	0	2.8
417505	7.87 (200)	8.63 (219)	4.73 (120)	0	6.6			
		Metric to Metric	417417	1.57 (40)	2.95 (75)	3.3 (85)	0	1
			417416	1.57 (40)	1.97 (50)	3.3 (85)	0	0.5
			419826	1.97 (50)	2.95 (75)	3.5 (88)	0	1
			417018	1.97 (50)	4.33 (110)	4.4 (113)	0	1
			419828	2.95 (75)	4.33 (110)	4.1 (105)	0	1
			419780	4.33 (110)	4.92 (125)	4.2 (107)	0	1.2
			419830	4.33 (110)	6.30 (160)	5.0 (126)	0	1
			419811	4.92 (125)	6.30 (160)	5.9 (150)	0	1.9
			419441	6.30 (160)	7.87 (200)	6.7 (170)	0	3.8
			417133	7.87 (200)	9.84 (250)	7.1 (180)	0	5.8
417217	9.84 (250)	12.40 (315)	7.5 (190)	0	9.7			

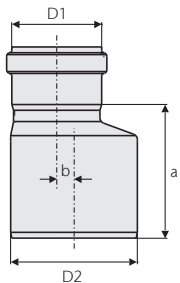
		Part No. AISI 316L	D1 in (mm)	D2 in (mm)	a in (mm)	b in (mm)	Weight lbs
Eccentric Couplings		417418	1.57 (40)	1.97 (50)	3.3 (85)	0.2 (5)	0.5
		417419	1.57 (40)	2.95 (75)	3.3 (85)	0.7 (18)	0.5
		98892	1.97 (50)	2.95 (75)	3.5 (88)	0.3 (7)	0.6
		98978	1.97 (50)	4.33 (110)	4.1 (103)	1.0 (25)	0.9
		98894	2.95 (75)	4.33 (110)	4.6 (116)	0.6 (15)	1.1
		98896	4.33 (110)	6.30 (160)	4.8 (123)	0.9 (22)	2.6
		TBD	6.30 (160)	7.87 (200)	5.7 (146)	0.8 (20)	4.4
		417135	7.87 (200)	9.84 (250)	7.1 (180)	0.6 (15)	5.8
		417218	9.84 (250)	12.40 (315)	7.5 (190)	0.6 (15)	9.7

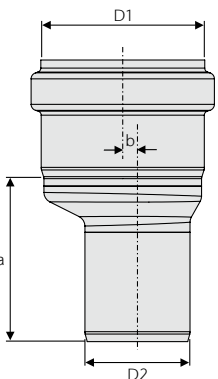
		Part No.	D1 in (mm)	D2 in (mm)	a in (mm)	b in (mm)	Weight lbs
Eccentric Couplings		419322	2.95 (75)	1.97 (50)	3.2 (82)	0.3 (7)	0.7
		419324	4.33 (110)	1.97 (50)	3.5 (88)	1.0 (25)	1
		419326	4.33 (110)	2.95 (75)	3.6 (91)	0.6 (15)	1.1
		419328	6.30 (160)	4.33 (110)	5.4 (136)	0.9 (22)	2.4

Parts Tables: Accessories

	Part No. AISI 316L	D1 in (mm)	D2 in (mm)	D3 in (mm)	D4 in (mm)	a in (mm)	Weight lbs
Connector with Socket and Flange	419264	1.97 (50)	1.57 (40)	4.3 (110)	7.6 (192)	5.9 (150)	5.1
	419265	1.97 (50)	1.97 (50)	4.9 (125)	7.7 (195)	6.5 (165)	5.9
	419266	2.95 (75)	2.56 (65)	5.7 (145)	9.6 (245)	7.3 (185)	7.5
	419267	4.33 (110)	3.94 (100)	7.1 (180)	10.2 (259)	8.7 (220)	10.8
	419540	6.30 (160)	5.91 (150)	9.4 (240)	7.9 (200)	11.2 (285)	18.7
	419541	7.87 (200)	7.87 (200)	11.6 (295)	9.4 (240)	13.4 (340)	27.1

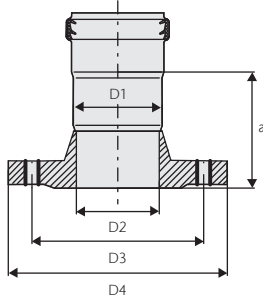

*Note: Further flange information available on request.

	Part No. AISI 316L	D1 in (mm)	D2 in (mm)	D3 in (mm)	D4 in (mm)	a in (mm)	Weight lbs
Connector with Spigot and Flange	419256	1.97 (50)	1.57 (40)	4.3 (110)	3.9 (100)	5.9 (150)	5.1
	419258	1.97 (50)	1.97 (50)	4.9 (125)	3.9 (100)	6.5 (165)	5.9
	419260	2.95 (75)	2.56 (65)	5.7 (145)	3.9 (100)	7.3 (185)	7.5
	419262	4.33 (110)	3.94 (100)	7.1 (180)	3.9 (100)	8.7 (220)	10.8
	419514	7.87 (200)	7.87 (200)	11.6 (295)	4.2 (102)	13.4 (340)	26.4

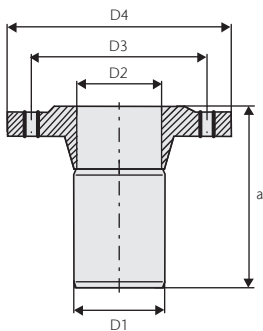

*Note: Further flange information available on request.

	Part No. AISI 316L	D in (mm)	a in (mm)	b in (mm)	Weight lbs
Access Unit	98963	2.95 (75)	5.5 (139)	3.5 (90)	1.5
	98965	4.33 (110)	7.2 (183)	4.6 (117)	2.9
	419785	4.92 (125)	8.3 (210)	5.3 (135)	3.5
	98967-BD	6.30 (160)	11.3 (288)	7.2 (184)	6.8
	419678	7.87 (200)	11.5 (293)	7.3 (186)	8.7
	417128	9.84 (250)	11.4 (290)	7.2 (184)	11.2
	417214	10.40 (315)	13.4 (340)	9.0 (228)	19.6

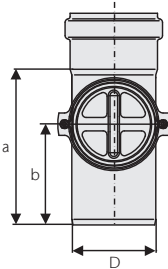

	Part No. AISI 316L	D1 in (mm)	D2 in (mm)	L in (mm)	Weight lbs
Rat Stop	419270	4.33 (110)	9.84 (250)	34.1 (864)	8.4

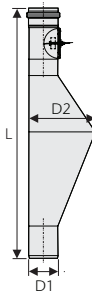

	Part No. AISI 316L	D in (mm)	Weight lbs
Vent Cowl	98962-BD	4.33 (110)	8.4

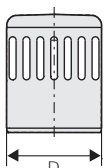

EPDM seals are supplied as standard. For more aggressive applications, FPM & NBR seals are available. Contact ACO.

Parts Tables: Accessories (cont.)

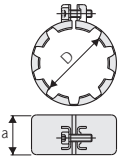
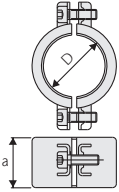
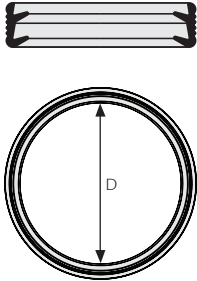
		Part No.	D in (mm)	a in (mm)	Weight lbs		
AP Socket Clamp		417067	1.97 (50)	1.6 (40)	0.2		
		417069	2.95 (75)	1.6 (40)	0.4		
		417227	4.33 (110)	1.7 (43)	0.7		
AP Socket Clamp - Two Part		417397	1.57 (40)	1.4 (36)	0.4		
		417025	1.97 (50)	1.6 (40)	0.4		
		417027	2.95 (75)	1.6 (40)	0.5		
		417029	4.33 (110)	1.7 (43)	0.6		
		417017	4.92 (125)	1.8 (45)	0.8		
		417031	6.30 (160)	1.8 (45)	1.3		
		419983	7.87 (200)	1.8 (45)	1.1		
		417137	9.84 (250)	1.8 (45)	1.6		
		417219	10.40 (315)	1.9 (48)	2.1		
AP Pipe Seal (See page 28)		EPDM	417400	1.57 (40)	0.02	0.1	
			98400-BD	1.97 (50)	0.02	0.1	
			98401-BD	2.95 (75)	0.04	0.1	
			98402-BD	4.33 (110)	0.11	0.1	
			419453	4.92 (125)	0.13	0.2	
			98403-BD	6.30 (160)	0.18	0.2	
			98433-BD	7.87 (200)	0.22	0.2	
			417146	9.84 (250)	0.22	0.3	
			417222	12.40 (315)	0.22	0.7	
			NBR	417401	1.57 (40)	0.02	0.1
				417037	1.97 (50)	0.02	0.1
				417038	2.95 (75)	0.04	0.1
		417039		4.33 (110)	0.11	0.1	
		417041		4.92 (125)	0.13	0.2	
		417040		6.30 (160)	0.18	0.2	
		FPM (Viton)	417042	7.87 (200)	0.22	0.2	
			417148	9.84 (250)	0.22	0.3	
			417223	12.40 (315)	0.22	0.7	
			417538	1.57 (40)	0.02	0.1	
			98404-BD	1.97 (50)	0.02	0.1	
			98405-BD	2.95 (75)	0.04	0.1	
			98406-BD	4.33 (110)	0.11	0.1	
			419454	4.92 (125)	0.13	0.2	
			98407-BD	6.30 (160)	0.18	0.2	
98437	7.87 (200)		0.22	0.2			
417147	9.84 (250)		0.22	0.3			
417506	12.40 (315)		0.22	0.7			

*Note: Spare ACO Pipe seals are available for all pipe sizes. All seals incorporate the unique ACO Pipe double lip seal arrangement for increased reliability and security. Both seal materials are mechanically interchangeable thereby facilitating easy on-site upgrade from EPDM to FPM, for example. For seal installation instructions, refer to the appendices. To aid identification, the seals are color coded as follows: EPDM seals are BLACK. FPM seals are GREEN. NBR seals are BLACK.

Parts Tables: Accessories (cont.)

	Part No. AISI 316L	Unit	Weight lbs
ACO Universal Lubricant	E80350000	Tube	0.3
	E80350001	Bucket	2.2

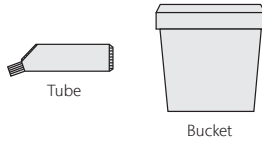

	Part No.	Unit	Weight lbs
Holder for Manual Cutting	419857	Ø125	7.7
	400742	Ø160	8.8
	400743	Ø200	9.9
	417166	Ø250	11.6

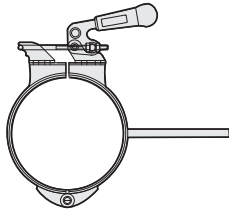

Installation Hardware

	Part No. AISI 316L	Part No. Galv Steel	D in (mm)	a in (mm)	Weight lbs
Fixing Plate	400521	400525	0.33 (8.4)	2.8 (70)	0.1

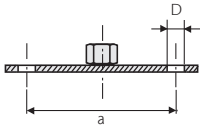

	Part No. AISI 316L	Weight lbs	Part No. Galv Steel	Weight lbs	D in (mm)
Support Bracket with Rubber Infill	417359	1	N/A	N/A	1.57 (40)
	400529	1	400533	0.9	1.97 (50)
	400530	1	400534	0.3	2.95 (75)
	400531	1	400535	0.7	4.33 (110)
	419855	1	419854	0.9	4.92 (125)
	400532	1	400536	0.9	6.30 (160)
	419675	1	419451	1	7.87 (200)
	417149	1.3	N/A	N/A	9.84 (250)
	417224	2.2	N/A	N/A	12.40 (315)

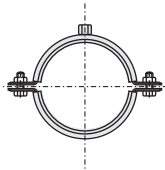

Installation Hardware (cont.)

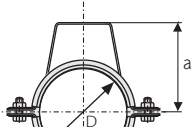
	Part No. AISI 316L	Part No. Galv Steel	D in (mm)	a in (mm)	Weight lbs
Support Bracket with Rubber Infill and Stirrup 	417358	417360	1.57 (40)	2.2 (56)	0.22
	400537	400541	1.97 (50)	2.2 (56)	0.4
	400538	400542	2.95 (75)	3.1 (80)	0.6
	400539	400543	4.33 (110)	4.6 (116)	0.9
	400540	400544	6.30 (160)	6.5 (166)	1.1

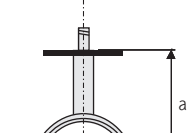
Support Bracket with Rubber Infill and Key 	417361	N/A	1.57 (40)	4.7 (120)	0.22
	400545	400549	1.97 (50)	4.7 (120)	0.4
	400546	400550	2.95 (75)	5.2 (133)	0.6
	400547	400551	4.33 (110)	5.9 (150)	0.8
	400548	400552	6.30 (160)	6.9 (175)	1

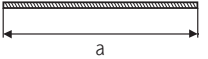
Threaded Support Pole M8 	400553	400557	M8	39.4 (1000)	0.86
	400554	400558	M8	3.5 (90)	0.07
	400555	400559	M8	1.6 (40)	0.04

	Part No. AISI 316L	Part No. Galv Steel	Weight lbs
Fixing Plate 	400561	400565	0.24

Installation - Pipe Assembly

Installation of ACO Pipe should be in accordance with recommendations below and per local plumbing codes.

Ensure that all tools are in good condition. Pipe stands must be stable to carry pipe with no movement and there must be no carbon steel or abrasive material in contact with the stainless steel pipe material.

PIPE ASSEMBLY

The assembly of pipe joints is quick and straightforward, requiring only a light application of lubricant. See page 22.

1. Make sure both ends are clean and free of dirt, and have a chamfer to assist in assembly.
2. Make sure that the correct seal is in place. See pages 21 and 28.
3. Ensure that the mating ends of the pipes and fittings are clean and free from contamination. Push-fit the pipe end into the socket but do not wedge into the socket recess. Use a half rotational movement to the right and left when pipe is pushed into the fitting.
4. When the pipes are fully engaged, pull the pipe back 0.25" - 0.50" (6 mm to 12 mm) to allow for thermal expansion. With a 60° temperature rise, stainless steel expands at a rate of 0.036" per yard (0.99 mm per meter).

PIPE CUTTING

If it is necessary to adapt or shorten pipe lengths, the cut must be square, clean and free of burrs prior to making the connection. If possible, use a pipe cutter to give smooth perpendicular cuts with chamfer on pipe end.

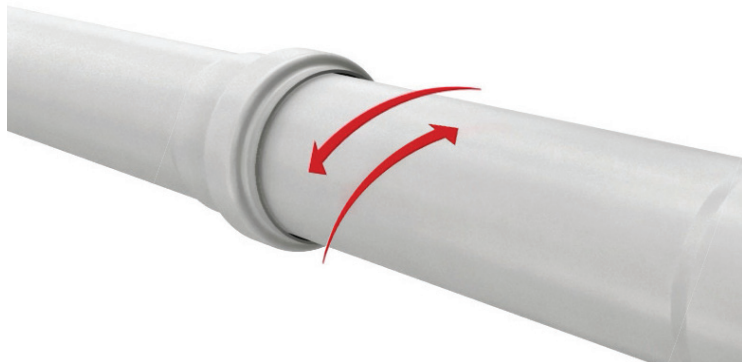

Installation - Pipework Protection

Installation of ACO Pipe should be in accordance with the recommendations below and meet local plumbing codes.

BELOW GROUND INSTALLATION

When pipework is installed underground, place the pipe in a sandy bed of 3" (75 mm) (minimum thickness) free of small gravel, sticks, etc. The sand should be free of chlorides and salt.

During installation, avoid scratching surface of the stainless with carbon steel. Avoid subjecting stainless steel pipes to welding and grinding airborne hot particles, metal shavings, and chemicals which may cause corrosion.

SOIL COVER

Where pipework is to be installed beneath a water table, apply the following soil depths:

Pipe Diameter - 50, 75, 110	
Low density soil 0.94 lbs/ft ³ (15kg/m ³)	16"
High density soil 1.44 lbs/ft ³ (23kg/m ³)	15"
Pipe Diameter - 125, 160, 200	
Low density soil 0.94 lbs/ft ³ (15kg/m ³)	23"
High density soil 1.44 lbs/ft ³ (23kg/m ³)	26"

Where ground is permanently cold as experienced in some northern areas, then the drainage may need to be heated.

In general, the minimum permissible depth to avoid winter freezing of water is 32" (800 mm). Note this recommendation is applicable where the ground thaws during spring and becomes warmer during summer.

Backfilling around the pipe can only start when the position of the pipe has been checked and approved.

STRUCTURAL PENETRATIONS

Where it is necessary for pipework to pass through the walls, structural decking or floors with waterproofing, appropriate seal systems have to be vetted.

SOCKET CLAMPS

ACO Pipe pipes and fittings include push-fit socket joints. These will not be able to resist internal pressure beyond design limits (0.5 bar) unless precautions are made to ensure that the joints do not slide open.

In many cases, appropriate fixing to the building can overcome this. If impossible to fix pipes to the building, socket clamps, see page 21, can prevent the push-fit sockets and spigot ends from opening in the event of excessive internal pressurization.

ACO Pipe socketed joints with socket clamps can withstand the following pressures:

Pipe Diameter in (mm)	Maximum Pressure Bar	PSI
1.57 (40)	2.5	36
1.97 (50)	2.5	36
2.95 (75)	2.5	36
4.33 (110)	2.5	36
4.92 (125)	2.5	36
6.30 (160)	1.5	36
7.87 (200)	1.5	21
9.84 (250)	1.0	14
12.40 (315)	0.7	10

Negative pressure (vacuum) applications of up to -0.8 bar can be accommodated.

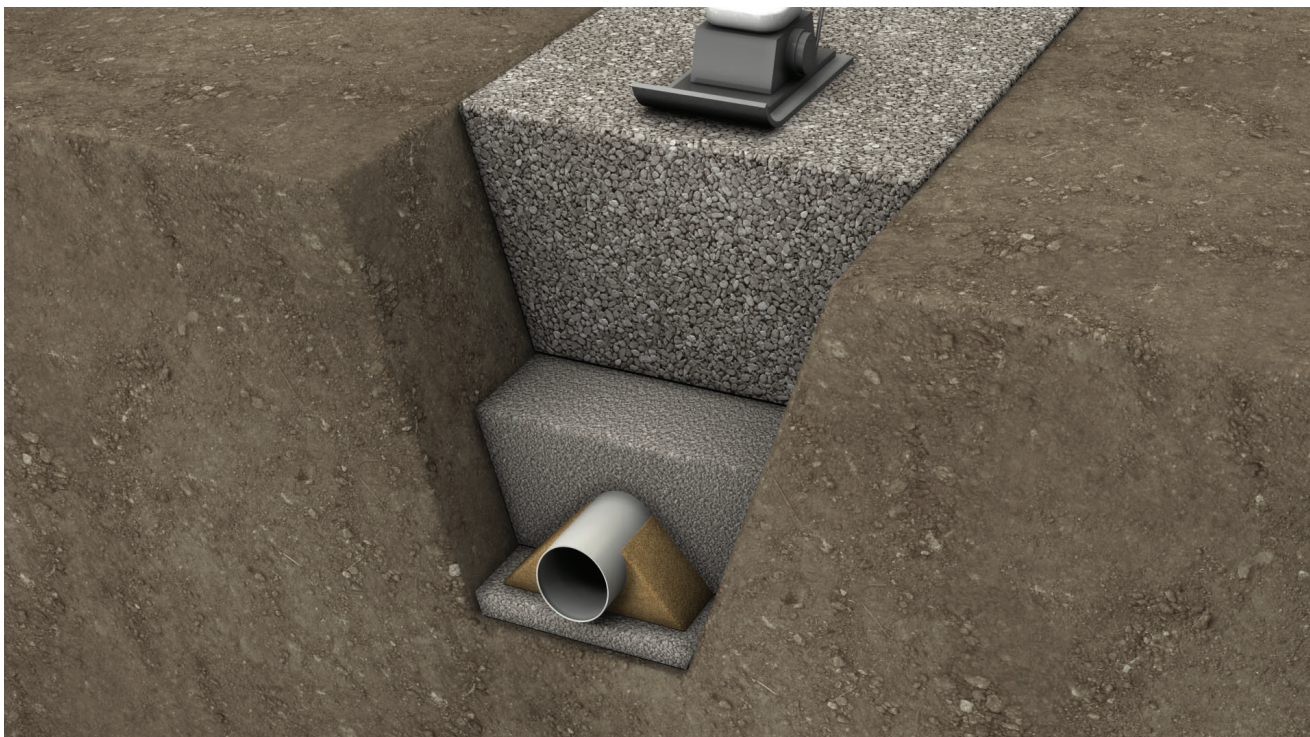

Pipework Support Details

HORIZONTAL PIPEWORK

The installer should ensure that the pipe is adequately supported. Generally, when the pipe is full of water, the vertical deflection of the pipe between brackets should not exceed 0.06" (1.5 mm).

As a guide, use table below for bracket spacing on horizontal pipes.

Pipe Diameter in (mm)	Bracket Spacing ft (m)
1.57 (40)	6.56 (2.0)
1.97 (50)	6.56 (2.0)
2.95 (75)	7.54 (2.3)
4.33 (110)	8.20 (2.5)
4.92 (125)	9.84 (3.0)
6.30 (160)	9.84 (3.0)
7.87 (200)	9.84 (3.0)
9.84 (250)	9.84 (3.0)
12.40 (315)	9.84 (3.0)

VERTICAL PIPEWORK

The load applied with fluid in the pipe is vertical. Position the highest bracket adjacent to the top inlet of the pipe, then mount brackets at 9'-10" (3 meter) spacings. At the bottom of the vertical pipe, use a bracket within 8" (200 mm) of the bottom. Fit brackets at each change of pipework direction or junction points.

The venting of vertical stacks should be in compliance with local plumbing codes. Pipework should be at least 1.4" (35 mm) from the wall to facilitate maintenance and painting.

MINIMUM AND MAXIMUM PIPE WEIGHTS

To assist designers and installers with the selection of appropriate pipe supports, the table below sets out the weights for all pipe sizes.

Pipe Diameter in (mm)	Pipe Weight lbs/ft (kg/m)	
	Empty	Full
1.57 (40)	0.41 (0.9)	1.02 (2.3)
1.97 (50)	0.81 (1.2)	2.02 (3.0)
2.95 (75)	1.21 (1.8)	4.64 (6.9)
4.33 (110)	1.81 (2.7)	8.00 (12.9)
4.92 (125)	2.22 (3.3)	10.68 (15.9)
6.30 (160)	3.36 (5.0)	16.53 (24.6)
7.87 (200)	5.04 (7.5)	25.53 (38.0)
9.84 (250)	4.18 (9.2)	20.45 (45.0)
12.40 (315)	7.00 (15.4)	32.27 (71.0)

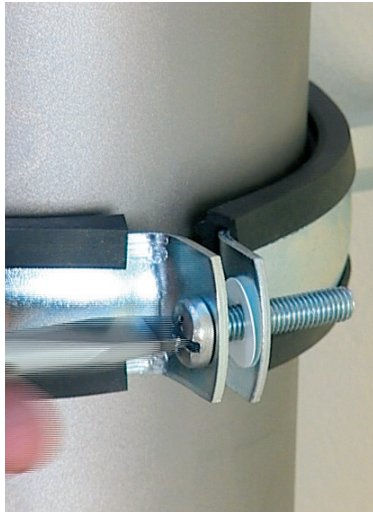

Care and Maintenance

All grades of stainless steel will stain and discolour due to surface deposits and can never be 100% maintenance free. In order to achieve maximum corrosion resistance, the surface of the stainless steel must be kept clean.

FACTORS AFFECTING MAINTENANCE

Surface contamination and the formation of deposits must be prevented in order to maintain a durable and hygienic surface.

These deposits may be minute particles of iron or rust from other materials used on the building site which have come in contact with the pipework. Care must be taken to avoid the cutting of carbon steels—including rebar—and the storage and erection of scaffolding, near

the pipework. Industrial and even naturally occurring atmospheric conditions can produce deposits that can also be corrosive, e.g. salt deposits from marine conditions.

The working environment can also produce corrosive conditions e.g. high humidity, such as in a swimming pool, increasing the speed of discolouration and therefore requiring maintenance to be carried out on a more frequent basis. Many cleaners, sterilizers and bleaches, when used in accordance with manufacturers' instructions are safe, but if used incorrectly (e.g. warm or concentrated), they can cause discoloration and corrosion on the surface of any quality of stainless steel.

Strong acid solutions are sometimes used to clean masonry and tiles but they should never be permitted to come into contact with metals, including stainless steel. If this should happen the acid solution must be removed immediately by dousing with clean water.

Wire brushes and wire wool must not be used to remove marks or cement spillage as this can introduce iron impurities onto the material surface.



Problem	Cleaning Agent	Comment
Routine cleaning	Soap or mild detergent and water (such as dishsoap or washing up liquid).	Sponge, rinse with clean water, and wipe dry if necessary.
Fingerprints	Soap or warm water or organic solvent (e.g. acetone, alcohol).	Rinse with clean water, wipe dry if necessary.
Stubborn stains and discoloration	Mild cleaning solutions	Rinse well with clean water and wipe dry.
Oil and grease marks	Organic solvents (e.g. acetone, alcohol).	Clean after with soap and water, rinse with clean water and dry.
Rust and other corrosion products	Oxalic acid. The cleaning solution should be applied with a swab and allowed to stand for 15–20 minutes before being washed away with water.	Rinse well with clean water (precautions for acid cleaners should be observed).

Seal Material Data

ACO Pipe sockets are fitted with EPDM seals as standard for regular drainage applications. For particularly aggressive applications, FPM and NBR seals are available. See page 21. Refer to the table below to assess suitability and then contact ACO.

EPDM (Ethylene Propylene Diene Monomer)

EPDM was originally developed during the 1950s for vehicle tire applications. It reached wider applications because of its suitability for outdoor use.

FPM (Fluoroelastomer)

FPM is a fluorocarbon and the best material for resistance to hostile chemical and oil environments at normal and elevated temperatures. This material is widely used in the chemical and pharmaceutical industries, but is significantly more expensive than EPDM.

NBR (Nitrile Rubber)

NBR has good water resistance, excellent chemical resistance and durability.



Seal Assembly Replacement or Upgrade

The double lip seal is easily removed and replaced from the female end of all ACO Pipe pipes and fittings. This allows for easy upgrade of the seal material prior to installation.

Seal Installation Notes

1. If changing the seal, ensure correct size and grade of seal is selected for the application (see table below).
2. Ensure the seal itself and the zone around the pipe and/or fitting receiving the seal is clean, dry and free from dust, grit and any metallic particles.
3. Insert the dry seal into the pipe and/or fitting recess. NOTE: the seal MUST be inserted so the double sealing lips face away from the opening of the pipe and/or fitting.
4. Do not use tools to aid the assembly process otherwise damage to the pipes, fittings and seals may occur.

Problem		EPDM	NBR	FPM
Water Resistance		Excellent	Good	Good
Chemical Resistance	Acids	Good	Excellent	Excellent
	Bases	Good	Good	Good
Solvent Resistance (68°F)	Alcohol	Good	Good	Good
	Acetone	Good	Not Recommended	Not Recommended
	Benzene	Not Recommended	Not Recommended	Good
Oil Resistance	ASTM Oil No. 1 @ 68°F @ 212°F	Fair	Excellent	Excellent
		Not Recommended	302°F Good	302°F Excellent
	ASTM Oil No. 3 @ 68°F @ 212°F	Not Recommended	Excellent	Excellent
		Not Recommended	302°F Good	302°F Excellent
Fuel Resistance	ASTM Fuel B	Not Recommended	Excellent	Excellent
Resistances	Oxidation	Excellent	Outstanding	Outstanding
	Ozone Weathering	Outstanding	Low	Outstanding
Heat Resistance	Maximum Continuous	266°F	176°F	401°F
	Maximum Intermittent	302°F	212°F	572°F
Low Temperature Resistance		-58°F	-22°F	-4°F
Gas Permeability		Fairly Low	Very Low	Very Low
Physical Strength		Good	Good	Good
Compression Set Resistance		Good	Good	Good
Tear & Abrasion Resistance		Good	Good	Good
Cost Factor (1 = low)		1	2	20

askACO

Every project brings its own requirements and challenges. In addition to our products, ACO offers you our knowledge and services to jointly develop tailor-made solutions from planning to after-sales support. With our extensive network of sales and support representation, ACO strives to ensure that the needs of your project are professionally and efficiently met.



train

Information and further education

At ACO, we share the expertise of the global ACO Group with architects, engineers, installers, and distributors who value quality. We invite you to benefit from it.



design

Planning and optimization

There are many drainage solutions to consider when planning a project. But which option leads to the most economically and technically safest solution? We help you to find the right answer.





support

Construction advice and presence

To prevent unpleasant surprises between planning and implementation stages, we advise and support you on a project-specific basis.



care

Inspection and maintenance

ACO products are designed and produced to last. With our after-sales support, we ensure that ACO will exceed your standards for years to come.

ACO ON THE WEB

You will find further information for our products on the ACO Building Drainage website. This allows you to access technical data, images, specifications, and installation instructions during planning.

www.acobd.com

www.askACO.ca

ACO products support the ACO System Chain



Building Drainage

- ACO Stainless - Stainless Trench Drains
- ACO BoxDrain - Stainless Floor Troughs
- ACO FloorDrain - Stainless Point Drains
- ACO Pipe - Stainless Push-fit Piping
- ACO ShowerDrain - Bathroom Drainage

Surface Water Management

- ACO Drain - Commercial Trench Drains
- ACO Infrastructure - Heavy Duty Drainage
- ACO Sport - Athletic Venue Drainage
- ACO StormBrixx - Geocellular Tanks
- ACO Aquaduct - Custom Drainage
- ACO Environment - Solid & Oil Separators
- ACO Wildlife - Guidance & Passage
- ACO Self - Garden & Landscape Drainage
- ACO UtilityDuct - Linear Ducting System

ACO Systems, Ltd.

East Sales Office
2910 Brighton Road
Oakville, ON L6H 5S3
Tel: (905) 829-0665
Toll Free: (888) 490-9552
Fax: (905) 829-2908

West Sales Office
#311 - 3602 Gilmore Way
Burnaby, BC V5G 4W9
Tel: (604) 554-0688
Fax: (604) 554-0693

info@acocan.ca
www.acocan.ca
www.acobd.com

© April 2022 ACO, Inc.

All reasonable care has been taken in compiling the information in this document. All recommendations and suggestions on the use of ACO products are made without guarantee since the conditions of use are beyond the control of the company. It is the customer's responsibility to ensure that each product is fit for its intended purpose and that the actual conditions of use are suitable. ACO, Inc. reserves the right to change products and specifications without notice.

Print #BD203

ACO. we care for water

